



APPLICANT: FILL IN ALL NON-SHADED INFORMATION - PLEASE PRINT

 <p>The Commonwealth of Massachusetts State Board of Building Regulations and Standards Massachusetts State Building Code 780 CMR</p>	 <p>Town of Grafton Building Department 30 Providence Road Tel: 508-839-5335 x 190 Fax: 508-839-4602 buildingdept@grafton-ma.gov</p>
---	--

APPLICATION TO INSTALL A SOLID FUEL BURNING STOVE OR INSERT

This Section For Official Use Only

Building Permit Number: _____	Date Issued: _____
-------------------------------	--------------------

Signature: _____ <small style="text-align: center;">Building Commissioner /Inspector of Buildings</small>	Date: _____
--	-------------

SECTION 1 - SITE INFORMATION	SECTION 2 – Use group: _____
-------------------------------------	-------------------------------------

1.1 Property Address: _____ _____	1.2 Assessors Map & Parcel Number: _____ <small style="text-align: center;">Map Number Lot/Parcel Number</small>
1.3 Location of Unit: _____	

SECTION 2 - PROPERTY OWNERSHIP/AUTHORIZED AGENT

2.1 Owner of Record:

Name: (Print) _____	Address : _____
Signature _____	Telephone: _____

2.2 Authorized Agent:

Name: (Print) _____	Address _____
Signature: _____	Telephone: _____

SECTION 3 - CONSTRUCTION SERVICES

3.1 License Construction Supervisor: Construction Supervisor: _____ Address _____ Signature _____ Telephone _____	Not Applicable <input type="checkbox"/> License Number _____ Expiration Date _____
---	--

3.2 Registered Home Improvement Contractor: Company Name _____ Address _____ Signature _____ Telephone _____	Not Applicable <input type="checkbox"/> Registration Number _____ Expiration Date _____
--	---

SECTION 4 - WORKERS' COMPENSATION INSURANCE AFFIDAVIT (M.G.L. c.152, S 25c(6))

Workers Compensation affidavit must be completed and submitted with this application. Failure to provide this affidavit will result in the denial of the issuance of the building permit.

Signed Affidavit Attached Yes..... No.....

SECTION 7a - OWNER AUTHORIZATION TO BE COMPLETED WHEN OWNERS AGENT OR CONTRACTOR APPLIES FOR BUILDING PERMIT	Homeowner authorizing an agent to obtain the building permit
<p>I _____; as Owner of the subject property hereby Authorize _____ to act on my behalf, in all matters relative to work authorized by this building permit application.</p> <p>_____ Signature of Owner Date</p>	
SECTION 7b - OWNER/AUTHORIZED AGENT DECLARATION	Person obtaining the building permit
<p>I _____; as Owner/Authorized Agent hereby declare that the statements and information on the foregoing application are true and accurate, to the best of my knowledge and belief.</p> <p>Signed under the pains and penalties of perjury.</p> <p>_____ Print Name</p> <p>_____ Signature of Owner/Agent Date</p>	

WOODSTOVE INSTALLATION CHECKLIST

Permit:

A permit is required for the installation of any solid fuel burning appliance. The permit and installation inspection are limited to the stove installation and not to the stove construction. Please supply all factory recommendations for stove installation including, venting, floor protection, requirements for vent termination (outside). **All fields must be filled out properly to guarantee processing of permit application.**

Stove:

- A) Type/radiant _____ circulating _____
- B) Manufacturer _____ test label _____
(after July 1, 1979 only)
- C) Name/Model No. _____ Collar size _____
- D) Dimensions/ Height: _____ Length _____ Width _____
- E) Testing Lab: _____ Date tested: _____

Chimney:

- A.) New _____ Existing _____
- B.) Size (flue area) _____
- C.) Other appliances attached to flue (number and flue size) _____
- D.) Metal (Manufacturer – name and type) _____
- E.) Masonry/Lined _____ Unlined _____
Flue liner _____
(type & manufacturer)
- F.) Height (refer to diagrams) _____ cap _____

Hearth: (min. 1 hr. fire resistance)

- a.) materials _____
- b.) sub-floor construction _____
- c.) minimum dimensions (refer to diagram) _____

Clearances and wall Protection (see stove installation clearances chart)

- a.) Type of wall protection provided _____
 b.) Clearances (refer to diagrams) _____

All documents supplied will become part of the application to be kept on file in the Building Department.

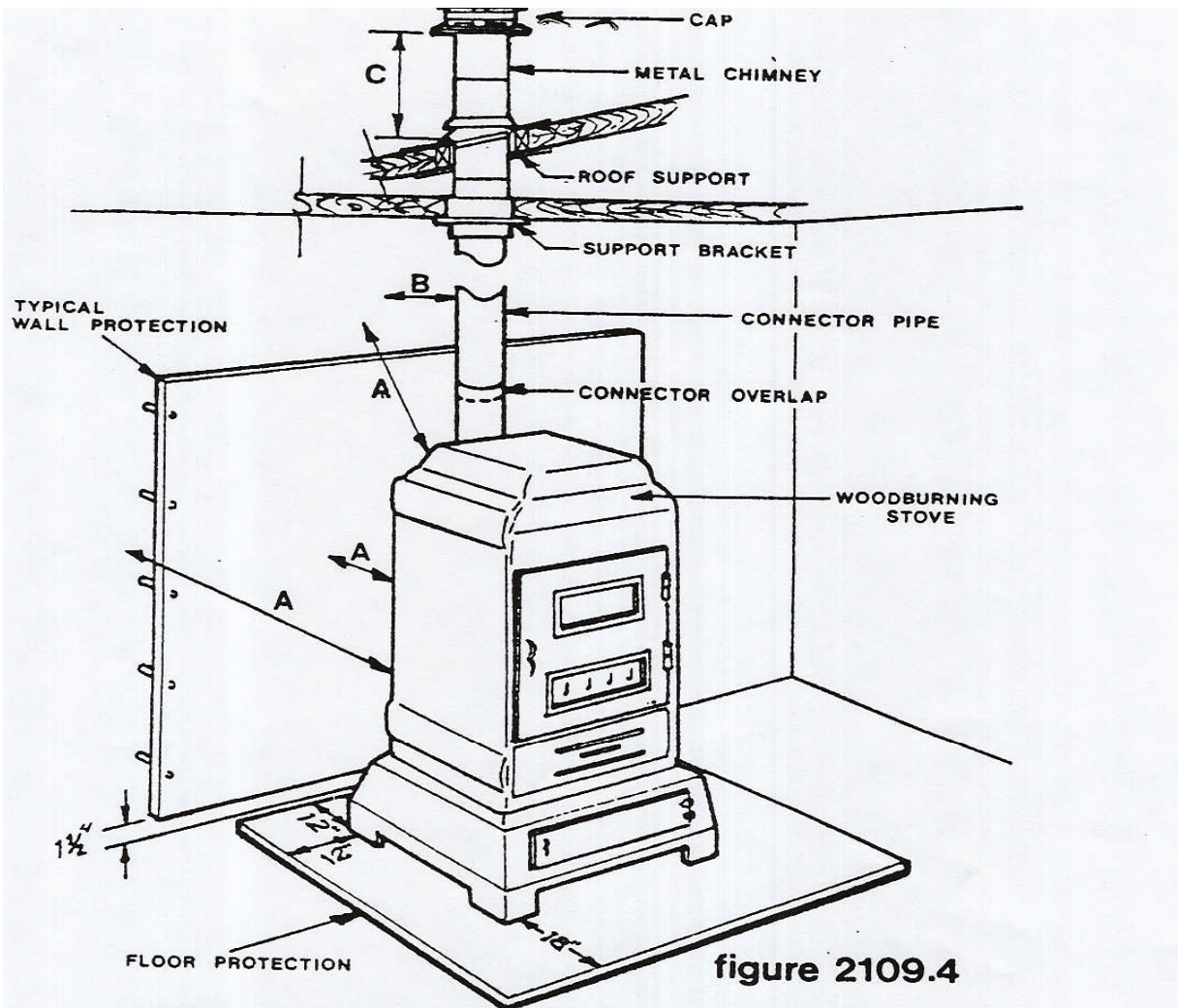

figure 2109.4

STOVE INSTALLATION CLEARANCES

Stove Components	TYPICAL WALL PROTECTION			
	Combustible Material	1" Asbestos Millboard Spaced Out 1"	Concrete/Masonry Foundation Wall	4" Brick Veneer
Radiant Stove —Front 1.	36"	—	—	—
Circulating Stove 1. —Front	24"	—	—	—
A. Radiant Stove —Side/Back 4.	36"	18"	6"	18"
A. Circulating Stove —Side/Back	12"	6"	6"	6"
B. Single Wall Connector Pipe 2.	18"	12"	6"	8"
B. Double Wall or Insulated Connector Pipe	9"	6"	4"	6"
C. Chimney Height (Metal or Masonry)	Three (3) feet above adjacent roof and two (2) feet above any roof ridges within 10 feet. If a damper is not included in the stove construction, it must be installed in the connector pipe.			
D. Damper				

1. Front: Fuel or ash access side.
2. Thimble required for passage through combustible construction.
3. Non-combustible spacers required.
4. Clearances on each side of a radiant stove with a heat shield shall be measured as if a circulating type.

SUGGESTED CHECKLIST FOR APPLICATION

- Copy of owner's installation manual
- Worker's Compensation Certificate
- Homeowner License Exemption (If applicable)
- Copy of Construction Supervisor License
- Copy of Home Improvement Registration (If applicable)
- All monies due to the town must be paid

Building Notes:
